

BOMAT PROFITHERM UP TO 2200 kW COMBUSTION OUTPUT

Heat exchangers for flue gas heat recovery, for boilers with pressure-jet gas or oil burners (other applications on request).



07-GG-1046-NT-4-K-6 ▲

Profitherm			Product number
06-GG-1046-NT-4-K-6	up to 1400 kW** combustion output	Flue gas inlet: Dint 355 Flue gas outlet: DN355 connector	94 679 20
07-GG-1046-NT-4-K-6	up to 1800 kW** combustion output	Flue gas inlet: Dint 405 Flue gas outlet: DN355 connector	94 680 20
08-GG-1046-NT-4-K-6	up to 2200 kW** combustion output	Flue gas inlet: Dint 405 Flue gas outlet: DN400 connector	94 681 20

Higher output ranges on request

FEATURES

- Ceramic heat exchanger
- Flow switch
- Deaerator
- 3-flange* flue gas outlet in polypropylene
- Condensate drain incl. condensate hose
- Insulation
- White coated sheet steel casing
- Water connections
- 3-flange* flue gas inlet
- BOMAT safety control panel incl. 120 °C flue gas temperature limiter for flue pipe; AWR pump control with cable and plug

ACCESSORIES

→ see page 37

* Choice of connection options

** Design basis: 160 °C flue gas inlet temperature, 40 °C average coolant temperature, Lambda 1.2.

To optimise energy savings the water inlet temperature should be in the 30-40 °C range under operating conditions.

FOOTPRINT AND CONNECTION DIMENSIONS

06-GG-1046-NT-4-K-6 bis 08-GG-1046-NT-4-K-6 Series

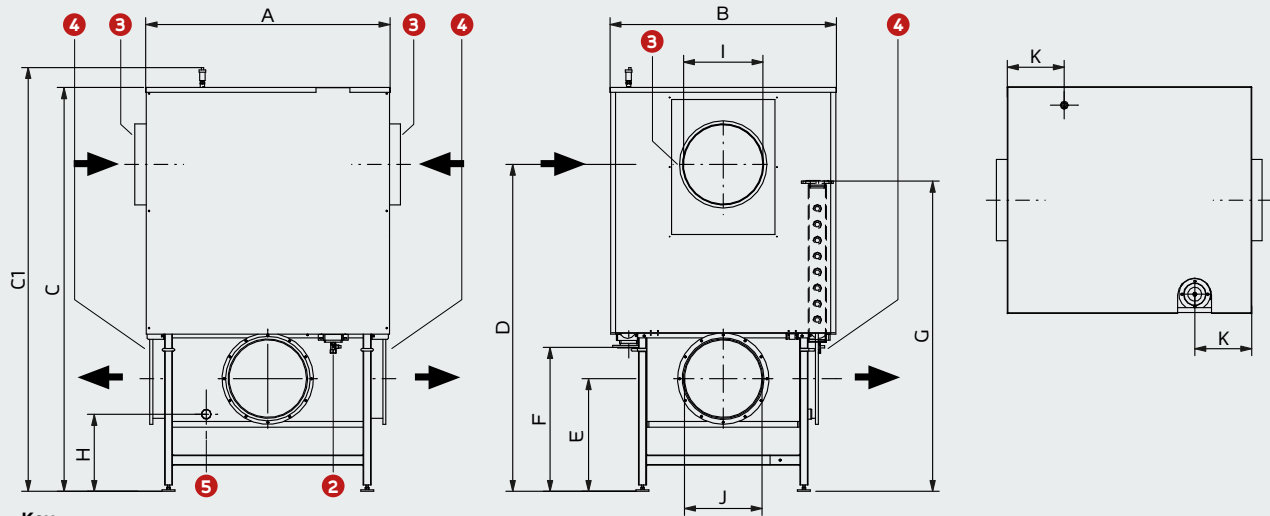

Key

- 1** Water inlet DN 65
- 2** Water outlet DN 65 with flow switch in top module
- 3** Flue gas inlet
- 4** Flue gas outlet
- 5** Condensate outlet Da 50

Profitherm →		06-GG-1046-NT	07-GG-1046-NT	08-GG-1046-NT
Boiler size (max. combustion output)	kW	1400	1800	2200
Water capacity	litres	98	112	127
Flue gas HLSC, max. setting	°C	120	120	120
Permissible operating pressure	bar	6	6	6
Max. permiss. flue gas inlet temp.	°C	250	250	250
Max. permiss. water outlet temp.	°C	80	80	80
Max. permiss. flue pressure drop	Pa	100	100	100
Weight	kg	542	595	647
Dimensions (mm)	A	1230	1230	1230
	B	1140	1140	1140
	C	2035	2035	2035
	C1	2135	2135	2135
	D	1565	1645	1725
	E	565	565	565
	F	725	725	725
	G	1560	1560	1560
	H	390	390	390
	I	Di 355	Di 405	Di 405
	J	Di 355	Di 355	Di 400
K	285	285	285	

Height-adjustable +/-10 mm using adjustable feet. All data is without guarantee. Subject to change without notice.

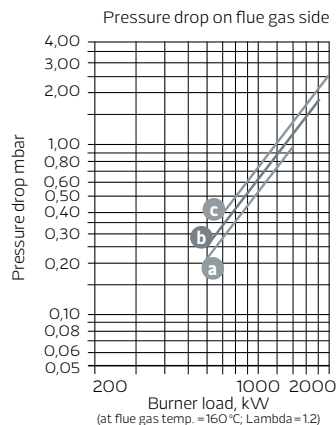
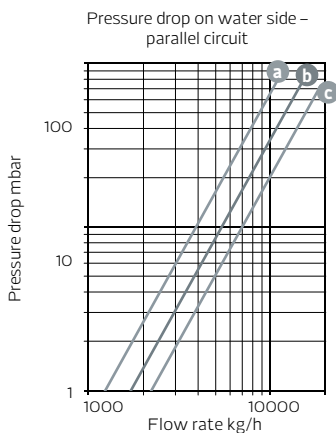

Key

- a** 06-GG-1046-NT-4-K-6
- b** 07-GG-1046-NT-4-K-6
- c** 08-GG-1046-NT-4-K-6